

CHART I International Protection (IP) Ratings to IEC 529

Protection Modes to EN 60529 DIN VDE 0470 Part 1			Second Digit – Degree of Water Protection									
			IP X0 No Protection	IP X1 Protection against dripping water falling vertically	IP X2 Protection against dripping water even when tilted 15° vertically	IP X3 Protection against dripping water even when tilted 60°	IP X4 Protection against splashing water from any direction	IP X5 Protection against water jets from any direction	IP X6 Protection against heavy seas from any direction	IP X7 Protection against effects of immersion	IP X8 Protection against submersion	
First Digit	Person touching	Protection against penetration of foreign bodies										
	IP 0X	No protection	No protection	IP 00								
IP 1X	Protection against touching with the hand	Protection against large solid bodies > 50mm Ø	IP 10	IP 11	IP 12							
IP 2X	Protection against touching with the finger	Protect. against med., solid bodies > 12.5 mm Ø	IP 20	IP 21	IP 22	IP 23						
IP 3X	Protection against touching with tools, wires, etc., > 2.5 mm Ø	Protection against small, solid bodies > 2.5 mm Ø	IP 30	IP 31	IP 32	IP 33	IP 34					
IP 4X	Protection against touching with tools, wires, etc., > 1 mm Ø	Protection against small, solid bodies > 1 mm Ø	IP 40	IP 41	IP 42	IP 43	IP 44					
IP 5X	Protection against touching with tools, wires, etc., > 1 mm Ø	Protection against internal dust accumulation	IP 50				IP 54	IP 55				
IP 6X	Protection against touching with tools, wires, etc., > 1 mm Ø	Protection against all dust penetration	IP 60					IP 65	IP 66	IP 67	IP 68	

In some countries a third digit is added. It gives information about the mechanical properties of the equipment. This designation has not yet been standardized according to current DIN and IEC regulations. Devices in this catalogue correspond to digit IP .7.

CHART II NEMA / IP Cross Reference

The chart below provides a cross-reference from NEMA to International Protection (IP) Ratings. This cross-reference is an approximation based on the most current information available. It is not sanctioned by NEMA, IEC, or any other regulatory body. This chart should be used only as a guideline.

IEC 529 Protection Ratings	NEMA Ratings									
	1	2	3	3R	4	4X	5	6	12	13
IP 00	↓									
IP 10		↓								
IP 11										
IP 20										
IP 21										
IP 22										
IP 23										
IP 30										
IP 31				↓						
IP 32										
IP 33										
IP 40										
IP 41										
IP 42										
IP 43										
IP 50							↓			
IP 51										
IP 52										
IP 53										
IP 54										
IP 55										↓
IP 56										
IP 60										
IP 61										
IP 62			↓							
IP 63										
IP 64										
IP 65					↓	↓				
IP 66							↓	↓		
IP 67									↓	
IP 68										

Properties of used Materials							
Material	Product	Temperature Resistance			Flammability Rating acc. to		Halogen Content
		Short-Term	Constant	Min. Temp.	UL 94	VDE 0471	
Polystyrene, flame resistant, impact resistant	TK-series (PS), RK-series, EK/AK/AKL Abox	80° C 176° F	70° C 158° F	-40° C -40° F	V - 2	960° C 1760° F	none*
Polycarbonate, glass fibre reinforced, flame-impact resistant	TK-series (PC-models), Nautic-series	130° C 266° F	120° C 248° F	-35° C -31° F	V - 1	960° C 1760° F	none
Polycarbonate, transparent	TK/EK/AK/AKL hinged door and transparent lid	130° C 266° F	120° C 248° F	-35° C -31° F	V - 2	850° C 1562° F	none
Thermoplastic Elastomer	Membrane plugs, membranes Abox 025/040	110° C 230° F	80° C 176° F	-30° C -22° F	HB	750° C 1382° F	none
Melaminrosin, Model 150	Installation terminals of the Nautic-series	120° C 248° F	100° C 212° F	-40° C -40° F	V - 1	960° C 1760° F	none
Polyethylene, flame resistant	Conduit adapters, twist nipples	100° C 212° F	70° C 158° F	-40° C -40° F	HB	960° C 1760° F	none
Polyurethane	Lid seals of all models	110° C 230° F	80° C 176° F	-35° C -31° F	--	650° C 1202° F	none
Aluminum Al 12Si	AL-series	130° C 266° F	100° C 212° F	-40° C -40° F	--		none
Polypropylene, flame resistant	HP-series	120° C 248° F	100° C 212° F	-30° C -22° F	V-2	960° C 1760° F	none*

All data given according to specifications of manufacturers; no guarantee from Altech/Spelsberg can be claimed.

* The basic material is halogen-free. Small amounts of halogen are contained in the flame proof finish of which approximately 6% is added to the materials.

Maximum permissible number of terminals and conductors to DIN 57606/VDE 0606									
The table below indicates the numbers of terminals and conductors which can be used in the respective Altech/Spelsberg junction box:									
Box Size Rated Cross-Section mm ²	Minimum Box Volume cm ³	Applies to Altech/Spelsberg Box Models	Number of Terminals and Conductors	Conductor cross section mm ²					
				1.5	2.5	4	6	10	16
2.5 mm ²	115 cm ³	HP 70/80 Abox 025	Terminal Conductor	6 20	5 15				
4 mm ²	200 cm ³	HP 90 Abox 040	Terminal Conductor	8 24	6 20	5 15			
6 mm ²	300 cm ³	HP 100 Abox 060	Terminal Conductor	10 30	8 24	6 20	5 15		
10 mm ²	500 cm ³	Abox 100	Terminal Conductor	12 36	10 30	8 24	6 20	5 15	
16 mm ²	825 cm ³	Abox 160	Terminal Conductor	18 54	15 45	12 36	8 24	6 20	5 15

Chemical Resistance Materials													
Material	Product	water	weak acid	strong acid	weak alkali	strong alkali	alcohol	benzene	benzol	mineral oil	diesel	vegetable fat	animal fat
		Polystyrene, flame resistant, impact resistant	TK Series (PS), RK Series, EK/AK/AKL Abox	●	●	◐	●	●	●	⊗	⊗	◐	⊗
Polycarbonate, glass fibre reinforced, flame-, impact resistant	TK Series (PC), Nautic Series	●	●	●	⊗	⊗	●	●	⊗	●	◐	●	●
Polycarbonate, transparent	TK/EK/AK/AKL hinged door and transparent lid	●	●	●	⊗	⊗	◐	◐	⊗	●	◐	●	●
Thermoplastic Elastomer	Membrane plug, membranes Abox 025/040	●	●	◐	●	◐	●	◐	◐	◐	◐	●	●
Melaminrosin, Model 150	Installation terminals of the Nautic Series	●	⊗	⊗	◐	⊗	●	●	●	●	●	●	●
Polyethylene, flame resistant	Conduit adapters, twist nipples	●	●	●	●	●	●	◐	⊗	◐	◐	●	●
Polyurethane	Lid seals for all models	●	◐	◐	◐	◐	◐	◐	◐	●	◐	●	●
Aluminum Al 12 Si	AL Series	●	●	◐	●	●	◐	●	⊗	●	●	◐	◐
Polypropylene, flame resistant	HP Series	●	●	◐	●	◐	●	◐	◐	●	◐	●	●
<p>● = resistant ◐ = limited resistance ⊗ = non-resistant</p>													

UV - Resistance									
<p>The degree of weather resistance given by the polycarbonate enclosures used is generally adequate. The enclosures have been tested under practical conditions in tropical regions for many years. If transparent lids are used, it is recommended to protect them against the direct effects of sun radiation.</p> <p>The American UL testing laboratories have approved several types of the PC series. A part of this examination is the test for UV resistance (UL 746 C).</p> <p>The weather proof test according to DIN 53 387 / 1000 hours was conducted at the "National Materials Testing Authority" in Dortmund.</p>									
Materials tested:	<table border="0"> <tr> <td>Polyethylene gray + black</td> <td>Polycarbonate, 15% GV, gray</td> </tr> <tr> <td>Polypropylene gray</td> <td>Polycarbonate, transparent</td> </tr> <tr> <td>TPE gray</td> <td>Polycarbonate, smoky topaz</td> </tr> <tr> <td>FS 131 gray</td> <td></td> </tr> </table>	Polyethylene gray + black	Polycarbonate, 15% GV, gray	Polypropylene gray	Polycarbonate, transparent	TPE gray	Polycarbonate, smoky topaz	FS 131 gray	
Polyethylene gray + black	Polycarbonate, 15% GV, gray								
Polypropylene gray	Polycarbonate, transparent								
TPE gray	Polycarbonate, smoky topaz								
FS 131 gray									
Note:	The test reports can be obtained from us free of charge.								
Shock-Testing by the Federal Office for Civil Defense									
<p>For installation in air raid shelters in accordance with standard test class RK 0.63/6.3, safety degree A. Devices up to an allowable weight of 2 kg are not subject to compulsory testing.</p> <p>Of the larger enclosures, the following types have been tested and approved:</p> <ul style="list-style-type: none"> • TK 2518, TK 3625 as empty enclosure • RK 2518, RK 3625 as serial terminal enclosure • EK 12, EK 24 as distribution box • AK 12, AK 24 as distribution board <p style="text-align: right;">(Application certificate 023/95)</p>									
Approval through «Bureau Veritas»									
<p>The following program series have been approved (Nr. 2661/2869/BO/OD) and are consequently suitable for installation in ships and shipyards:</p> <ul style="list-style-type: none"> • EK- Series distribution boards • Nautic- Series junction boxes • RK- Series terminal boxes • TK- Series empty enclosures 									
Polyurethane - sealing material									
<p>All enclosure types utilize a seal composed of a dual-component, specialty mixture. The seals are halogen-free, chemically resistant (see summary on pg. 165) and especially temperature resistant. The seals are inserted by robots, are exactly evenly distributed, and have a solid grip on the upper section of the enclosure. Consequently, a secure and safe respect reliable function of the seals is guaranteed.</p>									

Clearance Installation Heights for Spelsberg Enclosures

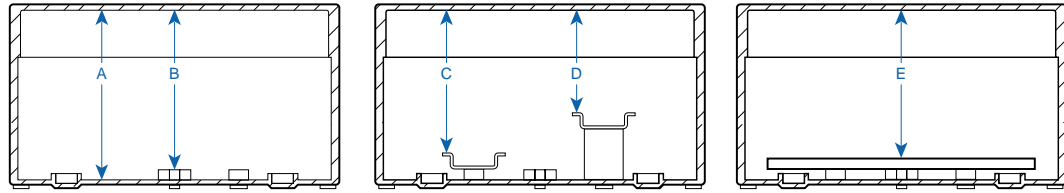

A) from base bottom
 B) from standoffs in base
 C) from top of mounting rail NS 35 (mounted on base standoffs)
 D) from top of mounting rail NS 35 (raised rail)
 E) from top of mounting plate
 [all dimensions in mm (in)]

Series	A	B	C	D	E
HP- Series					
HP 70/80	38.5 (1.52)	31.5 (1.24)	-	-	-
HP 90	40 (1.57)	33 (1.30)	-	-	-
HP 100	52.5 (2.07)	46.5 (1.83)	-	-	-
Abox- Junction boxes					
Abox 025	42 (1.65)	36 (1.42)	-	-	-
Abox 040	45 (1.77)	39 (1.54)	34 [TS 15] (1.34)	-	-
Abox 060	49 (1.93)	49 (1.93)	41.5 (1.63)	-	38.5 (1.52)
Abox 100	60 (2.36)	60 (2.36)	52.5 (2.07)	-	49.5 (1.95)
Abox 160	71 (2.80)	71 (2.80)	63.5 (2.50)	-	60.5 (2.38)
Abox 350	92 (3.62)	92 (3.62)	84.5 (3.33)	-	81.5 (3.21)
Nautic - Series					
Nautic 25/40/50	45 (1.77)	45 (1.77)	40 [TS 15] (1.57)	-	36 (1.42)
Nautic 60	53 (2.09)	53 (2.09)	45.5 (1.79)	-	44 (1.73)
Nautic 100	63 (2.48)	63 (2.48)	55.5 (2.19)	-	54 (2.13)
Nautic 160/250	81 (3.19)	75 (2.95)	67.5 (2.66)	-	66 (2.60)
	103 (4.06)	97 (3.82)	89.5 (3.52)	-	94 (3.70)
	123 (4.84)	119 (4.69)	112 (4.41)	95.5 (3.76)	116.5 (4.59)
EK- Distribution boxes					
EK 002	69 (2.76)	69 (2.76)	63.5 (2.50)	-	60 (2.36)
EK 004/008/012/024	103 (4.06)	97 (3.82)	89.5 (3.52)	-	94 (3.70)
TK- Enclosures - low cover					
TK 77/97/99/1309/1809	45 (1.77)	45 (1.77)	40 (1.57)	-	36 (1.42)
TK 1111	53 (2.09)	53 (2.09)	45.5 (1.79)	-	44 (1.73)
TK 1313	63 (2.48)	63 (2.48)	55.5 (2.19)	-	54 (2.13)
TK 1811/1818/2518	81 (3.19)	75 (2.95)	67.5 (2.66)	-	72 (2.83)
TK 3625	103 (4.06)	97 (3.82)	89.5 (3.41)	-	94 (3.70)
TK- Enclosures - high cover					
TK 77/97/99/1309/1809	69 (2.72)	69 (2.72)	64.0 (2.52)	-	60 (2.36)
TK 1111	77 (3.03)	77 (3.03)	69.5 (2.74)	-	68 (2.68)
TK 1313	87 (3.43)	87 (3.43)	79.5 (3.13)	-	78 (3.07)
TK 1811/1818/2518	103 (4.06)	97 (3.82)	89.5 (3.52)	-	94 (3.70)
TK 3625	156 (6.14)	150 (5.90)	142.5 (5.61)	-	147 (5.79)
TK- Enclosures - extra high cover					
TK 1811/1818/2518 – 16	156 (6.14)	150 (5.90)	142.5 (5.61)	-	147.5 (5.81)
TK 1818/2518/3625 – 21	206 (8.11)	200 (7.87)	192.5 (7.58)	-	197.5 (7.78)

AK and AKL Knockout Details

End View
 AK - Bottom Only
 AKL - Top and Bottom

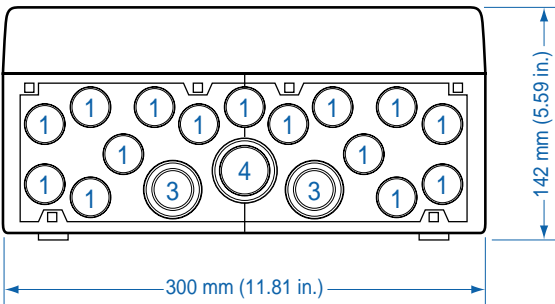

End View
 AK - Top Only

End View
 AK - Top Only

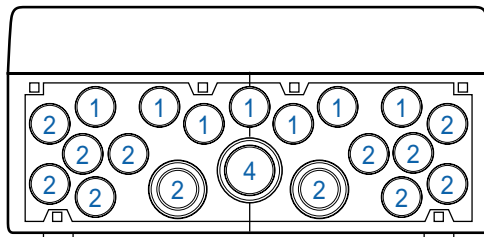

Side View
 AK
 AKL

Side View
 AKL / AKL

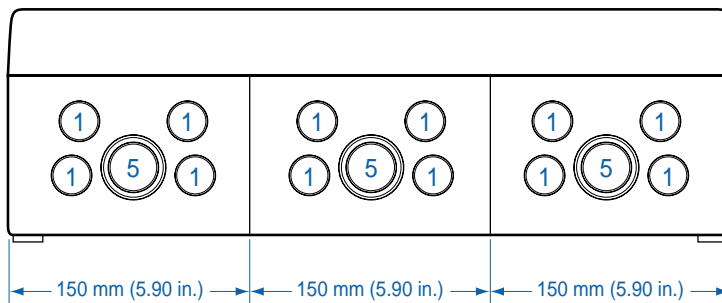

- ① = M20 (Knockout)
- ② = M20 (Installed Double Membrane Seal)
- ③ = M20/M25 (Knockout)
- ④ = M32/M40 (Knockout)
- ⑤ = M25/M32 (Knockout)