



# Bourdon Tube Pressure Gauges

## Solid-Front Turret Style Thermoplastic Case

Process Industry Series • Monel Wetted Parts • Type 26X.34

### Pressure Gauges

#### Application

Industrial type suitable for corrosive environments where the fluid medium does not clog connection or corrode wetted part material. Field convertible to a liquid filled gauge for severe vibration conditions. Solid front, blow-out back case design meets safety requirements of ASME B40.1.

#### Size

4½" (115 mm) dial size

#### Accuracy

± 0.5% of span (ASME B40.1 Grade 2A)

#### Ranges (All ranges not stocked)

Vacuum / Compound to 30" HG / 0 / 200 PSI  
Pressure from 15 PSI to 5,000 PSI  
or other equivalent units of pressure or vacuum

#### Working Range

Steady: Full scale value  
Fluctuating: 0.9 x full scale value  
Short time: 1.5 x full scale value

#### Operating Temperature

Ambient: -40°F to 150°F (-40°C to 65.6°C) <sup>Note 1</sup>  
Media: 500°F - dry gauge  
250°F - liquid filled

#### Temperature Error

Additional error when temperature changes from reference temperature of 68°F (20°C) ±1.5% per 100°F (37.8°C) rising or falling. Percentage of span.

### Standard Features

#### Connection

Material: Monel 405  
Lower mount (LM)  
1/4" NPT or 1/2" NPT with M4 internal tap

#### Bourdon Tube

Material: Monel 400  
30" Hg (Vac) to 1000 PSI C-type  
1500 PSI to 5000 PSI helical type

#### Movement

Copper alloy  
Internal stop pin at 1.3 times full scale value  
Overload and underload stops- standard  
Optional: dampened movement

#### Shock & Vibration

Shock resistance up to 100G  
Optional: up to 400G  
Optional: vibration resistance up to 10G

#### Cycle Testing

400,000- 2,000,000 \*cycles, depending upon pressure range  
\*Liquid filled

#### Dial

White aluminum with black lettering. Stop pin at 6 o'clock

#### Pointer

Adjustable black aluminum



#### Case

Black glass reinforced thermoplastic (PBTP)  
Solid front, blow-out back  
Turret style case with built in rear flange lugs

#### Weather Protection

Weather resistant (NEMA 3 / IP 54) - dry case  
Weather tight (NEMA 4X / IP 65) - liquid-filled case

#### Standard Scale

PSI

#### Window Gasket

Buna-N

#### Window

Acrylic

#### Case Filling

None - 212.34  
Glycerine - 213.34

#### Order Options (min. order may apply)

Overpressure protection up to 5x scale (limited ranges only)  
Threaded restrictor  
Silicone dampened movement  
Movement with PTFE coated gears  
Panel mounting adaptor kit (field assembled)  
Glycerine, silicone, or fluorolube case filling (263.34) <sup>Note 1</sup>  
Field conversion kit for glycerine, silicone, or fluorolube fill  
Cleaned for oxygen service  
Glass window  
Safety glass window  
Externally adjustable red drag pointer (max. hand)  
Externally adjustable red mark pointer  
Special connections limited to socket square size  
DIN standards  
Custom dial layout  
Other pressure scales available:  
Bar, kPa, MPa, Kg/cm<sup>2</sup>, and dual scales  
Alarm contact switches (magnetic or inductive)  
Shock resistant up to 400G  
Vibration resistant up to 10G  
Chemical seals available

Note 1 Temperature Ranges (Liquid filled gauges)  
Glycerine: -4°F to 150°F (-20°C to 65.6°C)  
Silicone: -40°F to 150°F (-40°C to 65.6°C)

**APM 26X.34**  
**(APM 02.10)**

**Dimensions:**

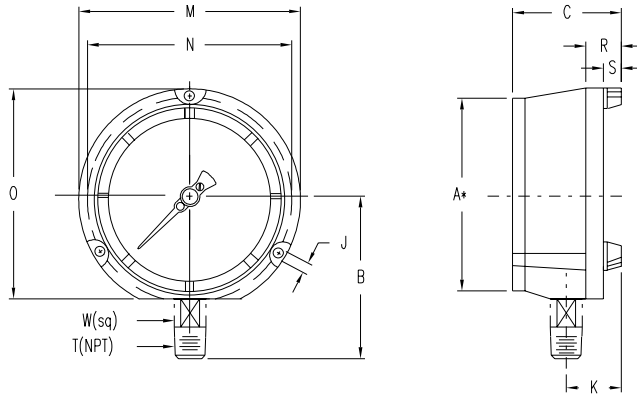

A\*NominalSize

| TYPE         | WEIGHT | KEY | A*  | B(1) | C    | J    | K    | M    | N     |
|--------------|--------|-----|-----|------|------|------|------|------|-------|
| 26X.34<br>LM | 3lbs.  | mm  | 114 | 103  | 82   | 6.0  | 38   | 148  | 136.5 |
|              |        | in  | 4.5 | 4.06 | 3.23 | 0.24 | 1.50 | 5.83 | 5.37  |

(1)Gaugeswith1/4"NPTconnection-dimensionchangesto97mm/3.81in.

THE MEASURE OF  
**Total Performance™**

**Ordering Information:**

State computer part number (if available) / type number / size / range / connection size and location / options required.

Specifications given in this price list represent the state of engineering at the time of printing. Modifications may take place and the specified materials may change without prior notice



**WIKAI Instrument Corporation**  
1000 Wiegand Boulevard  
Lawrenceville, Georgia 30043-5868  
Tel: 770-513-8200 Fax: 770-338-5118  
<http://www.wika.com> e-mail: [info@wika.com](mailto:info@wika.com)



### Chemical Seals

---

#### Cooling Element

Intended to protect the pressure instrument from high or low process temperature. Air flow across heat exchanging fins reduces or increases the temperature of the system fill fluid to protect the pressure measuring instrument.

The cooling element is recommended for process temperatures above 212°F. It is direct mounted between the pressure instrument and the chemical seal. Silicone fill is recommended. Effective temperature reductions of 200°F depending upon ambient conditions. All stainless steel construction back welded to stainless steel upper housing or flange.

#### Capillary line

Stainless steel capillary with or without stainless steel armor provides a connection between the pressure instrument and the chemical seal. It protects the pressure instrument from high or low process temperatures and provides distant or remote reading.

The capillary should be selected as short as possible, since changes in ambient temperature conditions may considerably affect the accuracy and response time of the pressure instrument. Standard length is five feet; other lengths are available upon request.

Installation on mechanical gauges normally requires a gauge support and gauge adaptor or other surface mounting provisions.

Any level difference between pressure instrument and chemical seal will cause a pressure indication error. The level difference can be compensated for during calibration of the chemical seal assembly if level difference is known.

Minor corrections can be made on site by means of an adjustable pointer or zero adjustment of the pressure instrument.

#### Gauge Support and Adaptor

Provides wall mounting of pressure instrument by clamping to gauge adaptor. Material: gauge support - aluminum or stainless steel, gauge adaptor - stainless steel.



Chemical Seal Assembly with Cooling Element



Chemical Seal Assembly with Capillary Line, Gauge Support and Adaptor

To determine the effects of temperature and response time in a specific application, contact the factory for an **Application Questionnaire**. The information provided will allow WIKA Technical Support to accurately model your application parameters using state-of-the-art computer simulation techniques.

Cooling Element

| T         | KEY | A    | B    |
|-----------|-----|------|------|
| 1/4"X1/4" | in. | 4.68 | 4.05 |
|           | mm  | 119  | 103  |
| 1/2"X1/2" | in. | 4.68 | 3.86 |
|           | mm  | 119  | 98   |

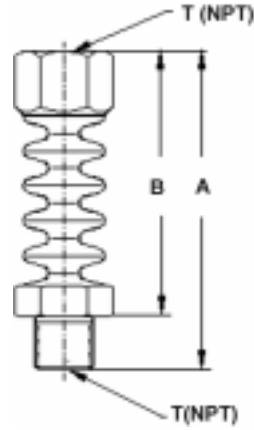

Capillary Line

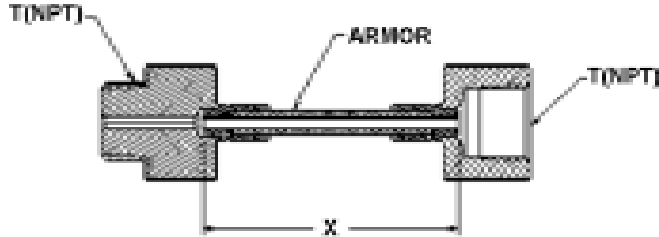

X = 5 feet standard, maximum 48 ft.; T = 1/4" or 1/2"

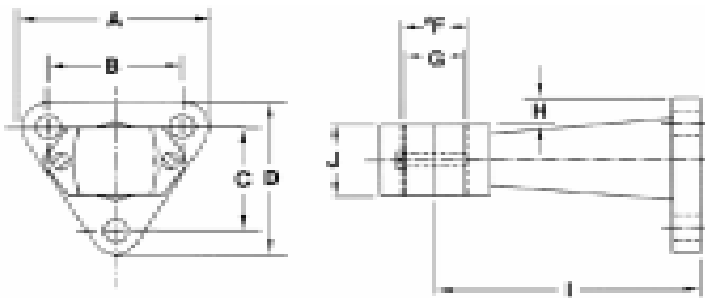

| KEY | A    | B    | C    | D    | E    | F    | G   | H   | I    |
|-----|------|------|------|------|------|------|-----|-----|------|
| in. | 3.35 | 2.56 | 2.20 | 2.99 | .276 | 1.02 | .87 | .55 | 3.94 |
| mm  | 85   | 65   | 56   | 76   | 7    | 26   | 22  | 14  | 100  |

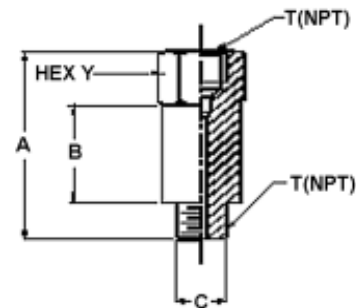

| KEY | A    | B    | C    | T    | Y    |
|-----|------|------|------|------|------|
| in. | 2.95 | 1.18 | 1.02 | 1/2" | 1.06 |
| mm  | 75   | 30   | 26   | --   | 27   |

THE MEASURE OF  
**Total Performance™**

**Ordering Information:**

State computer part number (if available) / type number / size / range / connection size and location / options required.

Specifications given in this price list represent the state of engineering at the time of printing. Modifications may take place and the specified materials may change without prior notice



**WIKAL Instrument Corporation**  
1000 Wiegand Boulevard  
Lawrenceville, Georgia 30043-5868  
Tel: 770-513-8200 Fax: 770-338-5118  
<http://www.wika.com> e-mail: [info@wika.com](mailto:info@wika.com)

# Chemical Seal Mounting Options

## Chemical Seal

### System Fill Fluids

The system fill fluid should be carefully selected for compatibility with the pressure medium. This is particularly true in food applications and in processes involving oxidizing media such as oxygen or chlorine. The table below lists the most common fill fluids. Alternate fill fluids are available for special applications.

Mounting Options available (connections, capillary, etc.)  
See Selection Guide (over)

**NOTE:** For applications with oxidizing media such as oxygen or chlorine, either Halocarbon (KN 21) or Fluorolube (KN8) should be used for the system fill.

| Fill Fluid <sup>1</sup>        | Standard     | Low Temp.      | Food Application       |                              |               |
|--------------------------------|--------------|----------------|------------------------|------------------------------|---------------|
|                                | Silicone Oil | Silicone Oil   | Glycerine <sup>3</sup> | Glycerine/Water <sup>3</sup> | Vegetal Oil   |
| Code No. (KN)                  | KN 2         | KN 17          | KN 7                   | KN 12                        | KN 13         |
| Temperature (min/max)          | -4 to +392°F | -130 to +176°F | +60 to +462°F          | +14 to +248°F                | +14 to +400°F |
| Assembly design:               | Part Number  | Part Number    | Part Number            | Part Number                  | Part Number   |
| - Mini Seal direct             | 281          |                | 280                    |                              | 287           |
| - Direct mounting <sup>2</sup> | 219          | 238            | 215                    | 216                          | 250           |
| - with cooling element         | 220          | 296            |                        |                              | 254           |
| - with capillary Upto 9'       | 220          | 296            |                        |                              | 254           |
| - with capillary 10' to 19'    | 221          | 269            |                        |                              | 255           |
| - with capillary 20' to 29'    | 222          | 273            |                        |                              | 256           |
| - with capillary Over 29'      | 223          |                | --                     |                              | 257           |

<sup>1</sup> Contact factory for other filling liquids.

<sup>2</sup> Not available for Type 990.28.

<sup>3</sup> KN 7 and KN 12 not suitable for vacuum or compound ranges

All threads  
+14° F when  
Temperature

# Mounting Options

DG,N/A,N,N,N,N,2,N

## Options

- 1 = Mounting bracket, aluminum
- 2 = Mounting bracket, stainless steel
- 3 = Back weld 360° (SS only)
- 4 = Tack weld (SS only)
- 5 = Volume minimized (To improve temperature effects, see note 4)
- N = Not applicable

## Fill Fluids

- 02 = KN 2, standard silicone oil (DC200-50)
- 03 = KN 3.2, high temperature silicone oil
- 07 = KN 7, glycerine (99.6% pure) (See note 2)
- 08 = KN 8, Fluorlube® FS-5 (See note 3)
- 12 = KN 12, glycerine / water (86.5% / 13.5%) (See note 2)
- 13 = KN 13, vegetable oil (See note 2)
- 17 = KN 17, low temperature silicone oil (4 cSt)
- 21 = KN 21, Halocarbon® (grade 6.3) (See note 3)
- 32 = KN 32, DC704 silicone oil (39 cSt)
- 34 = KN 34, food grade silicone oil (350 cSt) (See note 2)
- 59 = KN 59, Neobee® M-20 (77 cSt) (See note 2)
- ?? = KN ??, DC200-10 silicone oil (10 cSt)
- XX = Customer to specify
- NA = Not applicable

## Support tubes / Adaptors

- 4 = Support tube, 4" (See note 1)
- A = Stainless steel adaptor
- N = Not applicable

## Connection B (connection to seal/process)

- 1 = 1/4" NPT-F
- 2 = 1/4" NPT-F with fill port
- 3 = 1/2" NPT-F
- 4 = 1/2" NPT-F with fill port
- 5 = 1/4" NPT-M
- 6 = 1/4" NPT-M with fill port
- 7 = 1/2" NPT-M
- 8 = 1/2" NPT-M with fill port
- 9 = Welded to seal (See note 1)
- X = To be specified by customer
- N = Not applicable

## Connection A (connection to instrument)

- 1 = 1/4" NPT-F
- 2 = 1/4" NPT-F with fill port
- 3 = 1/2" NPT-F
- 4 = 1/2" NPT-F with fill port
- 5 = 1/4" NPT-M
- 6 = 1/4" NPT-M with fill port
- 7 = 1/2" NPT-M
- 8 = 1/2" NPT-M with fill port
- 9 = Welded to instrument (See note 1)
- X = To be specified by customer
- N = Not applicable

## Capillary Armor

- B = Capillary w/o protective armored tube
- A = Capillary with stainless steel armored tube
- P = Capillary with stainless steel armored tube, white PVC coating
- N = Not applicable

## Capillary ID (OD x wall thickness) identification color

- 2.0 = 2.0 mm (3 x 0.5 mm) yellow
- 1.0 = 1.0 mm (3 x 1.0 mm) green
- 0.6 = 0.6 mm (3 x 1.2 mm) black
- N/A = Not applicable

## Mounting and capillary length

- DG = Direct mount / gauge
- DT = Direct mount / transmitter
- DS = Direct mount / switch
- CC = Cooling element
- OX = Capillary length 1 to 9 feet, specify length (x) use 5ft. increments
- XX = Capillary length 10 to 50 feet, specify length (XX) use 5ft. increments

## Notes

1. For use with capillary only.
2. Food grade fill fluids.
3. Inert fill fluids.
4. Recommended for use with smart electronic transmitters.

Items in **bold** are available from stock (subject to prior sales).  
For optional items, consult factory for current lead-time.

## Ordering Information:

State computer part number (if available) / type number / size / range / connection size and location / options required.

Specifications given in this price list represent the state of engineering at the time of printing. Modifications may take place and the specified materials may change without prior notice



**WIKAI Instrument Corporation**

1000 Wiegand Boulevard  
Lawrenceville, Georgia 30043-5868  
Tel: 770-513-8200 Fax: 770-338-5118  
<http://www.wika.com> e-mail: