

Calibration Equipment

Due to the versatility, our Calibration Equipment is widely used throughout the inspection industry.

The MIC TRAC measurement center combines accuracy with flexibility to ideally adapt to the shop floor or to the quality lab. The proven accuracy makes the MIC TRAC a perfect choice for part inspection and serves as a setting master for gages produced by leading gage manufacturers. The unit comes in several lengths as well as different accuracies. Our MT-3000 series provides tolerance of .0001" and our MT-4000 series provides tolerance of .00003".

Customers who have implemented an in-house calibration system with the MIC TRAC not only realize a substantial savings, but achieve greater control over the inspection of their gauging equipment.

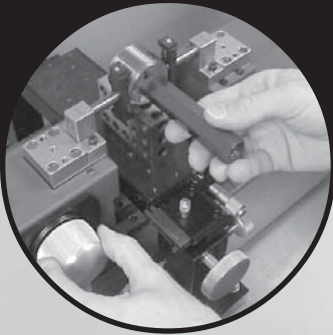

Threaded Plug

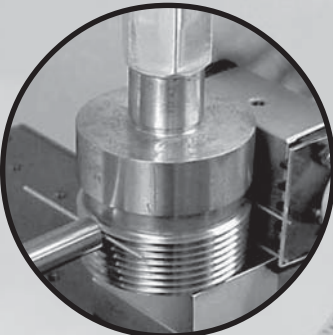

Tapered Plug

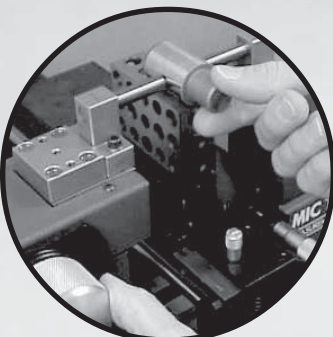

Cylindrical Plug

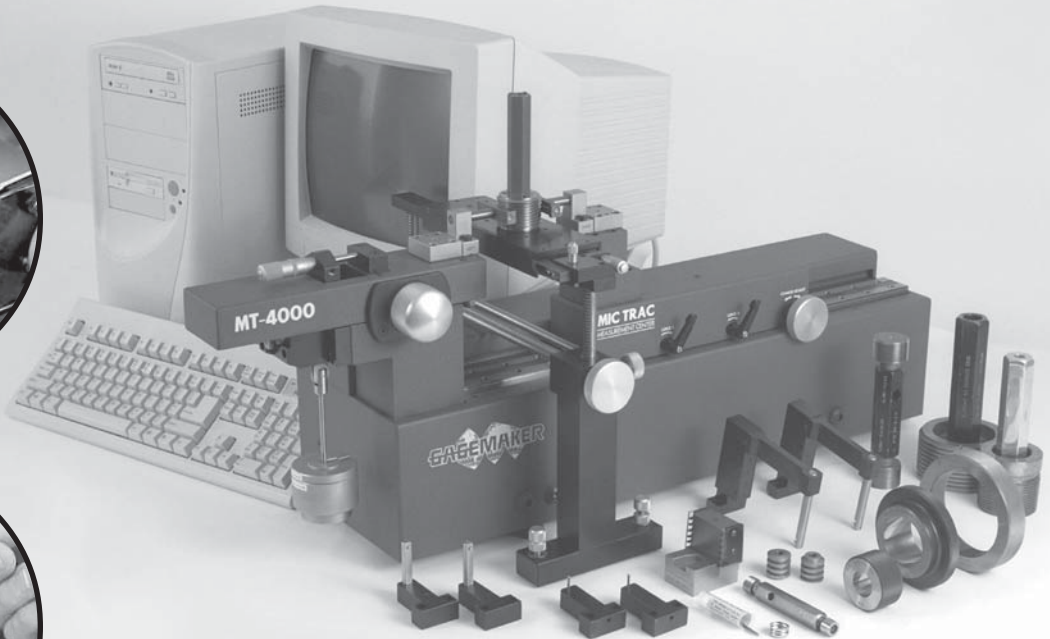

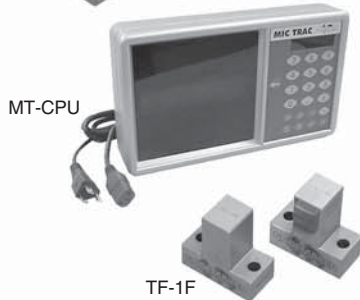

TAPERED SETTING BLOCKS

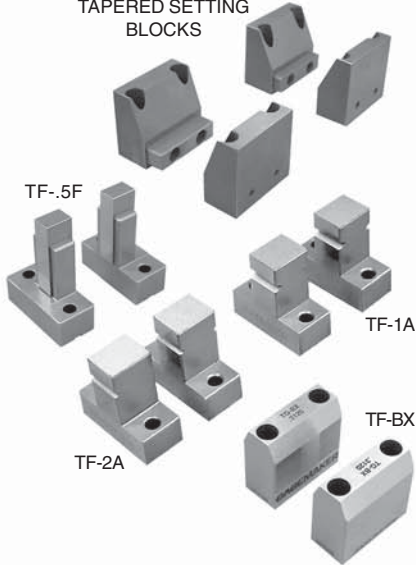

GAGE SETTING SYSTEM

This package features the MIC TRAC as a multi-use gage setting system. The system sets or zeros most gages with the use of interchangeable anvils or blocks. Standard resolution of base unit is .00005". Accuracies range from $\pm 0.0001"$ to $\pm 0.0004"$. (MT CPU is CE approved.)

MIC TRAC base unit w/ range: 0" to 12" with TF-1F blocks and shipping carton

MT-3012-50 BASIC GAGE SETTING SYSTEM

GAGE SETTING SYSTEM OPTIONS

Expand or upgrade the basic gage setting system with the addition of other accessories and setting blocks.

Model No.	Description	Unit Price
OTHER BASE UNITS (Includes TF-1F block set)		
MT-3012-50	MIC TRAC base unit w/ range: 0" to 12" internal, 1½" to 13½" external	
MT-3024-50	MIC TRAC base unit w/ range: 0" to 24" internal, 1½" to 25½" external	
MT-3036-50	MIC TRAC base unit w/ range: 0" to 36" internal, 1½" to 37½" external	
MT-3048-50	MIC TRAC base unit w/ range: 0" to 48" internal, 1½" to 49½" external	
MT-FL	Force-Lok Option	

TAPERED CYLINDER SETTING BLOCKS (2 block sets)

TF-10	Tapered setting blocks 10° half angle
TF-15	Tapered setting blocks 15° half angle
TF-20	Tapered setting blocks 20° half angle
TF-30	Tapered setting blocks 30° half angle
TF-45	Tapered setting blocks 45° half angle

SPECIAL PURPOSE SETTING BLOCKS

TF-.5F	Carbide Flat Face Setting Blocks (.750" outside dim.)
TF-1F	Flat face setting blocks (1.500" outside dim.)
TF-BX	23° angled face setting blocks

THREAD GAGE SETTING BLOCKS

TF-1V	1-5 pitch 60° "V" thread setting blocks
TF-2V	6-20 pitch 60° "V" thread setting blocks
TF-1A	2-3 pitch ACME/STUB ACME thread setting blocks
TF-2A	4-20 pitch ACME/STUB ACME thread setting blocks

HAND GAGE CALIBRATION SYSTEM

This package features the MIC TRAC as a multi-use gage calibration system. The system uses interchangeable anvils to calibrate a variety of handheld style gages. Through the various configurations of fixtures, the MIC TRAC achieves an accuracy of ± 0.0001 " (cumulative per every 12" of travel). Resolution is .00005". (MT CPU is CE approved.) **The standard package incorporates the ForceLok™ feature to provide the operator with a constant anvil force that improves repeatability from operator to operator.**

HGC-12-HT-FL HAND GAGE CALIBRATION PACKAGE

Package includes:

- MT-3012-50-FL MIC TRAC base unit w/ range: 0" to 12", includes TF-1F blocks and shipping carton.
- CAL-PAK, complete calibration fixture package
- CRC-MT3000 Calibration Reference Sheets - Calibration procedures for use with CAL-PAK

GAGE CALIBRATION SYSTEM OPTIONS

The following base units and accessories are available for larger requirements.

Model No.	Description	Unit Price
-----------	-------------	------------

OTHER PACKAGES

HGC-24-HT-FL	Above calibration package with MT-3024-50F, w/ range 0" to 24"	
HGC-36-HT-FL	Above calibration package with MT-3036-50F, w/ range 0" to 36"	
HGC-48-HT-FL	Above calibration package with MT-3048-50F, w/ range 0" to 48"	

SYSTEM PRINTER AND PAPER

PRN-100	Electronic printer for hardcopy records
PRN-000	Replacement printer paper

CALIBRATION ACCESSORY BLOCKS AND FIXTURES

CAL-PAK	Complete calibration package Includes: TF-IND, TF-DG, TF-CA, TF-SA, TF-TI, TF-SV, TF-SS, TF-VN, TF-MTL, and storage case
TF-IND	AGD dial indicator calibration fixture (includes .375" and 8mm bushing and TF-2F block)
TF-DG	Calibration fixture for depth micrometer *
TF-CA	Caliper calibration accessory dial, digital and vernier calipers. Includes TF-SA support arm.
TF-TI	Test indicator calibration block *
TF-SV	"V" Support accessory ** for calibrating micrometers and standards
TF-SS	Straight support accessory * for support of extended probes
TF-VN	"V" blocks for calibration of axial travel probes and bore gages
TF-MTL	Micrometer spindle thread lead calibration fixture.
TF-1F	Flat face setting block set (2 blocks) 1.5000" outside dimension
TF-BA	Base support block for setting dial bore gages **
TF-VB	"V" block fixture for calibration of Gagemaker's TH-3004 and MRP-2002 Upper arms *
TF-LG	Gagemaker lead gage calibration fixture *
TF-ALG	Lead gage calibration fixture *
TF-BI	Base support plate for setting dial bore gages ** * 1/TF-1F block required with this accessory ** 2/TF-1F blocks required with this accessory
CRC-MT4000	Complete procedural documentation for the calibration of handheld inspection equipment including; O.D. & I.D. micrometers, calipers, depth micrometers, ring and plug gages, and more.
CRC-MT3000	Complete procedural documentation for the calibration of handheld inspection equipment including; O.D. & I.D. micrometers, calipers, depth micrometers, ring and plug gages, and more.

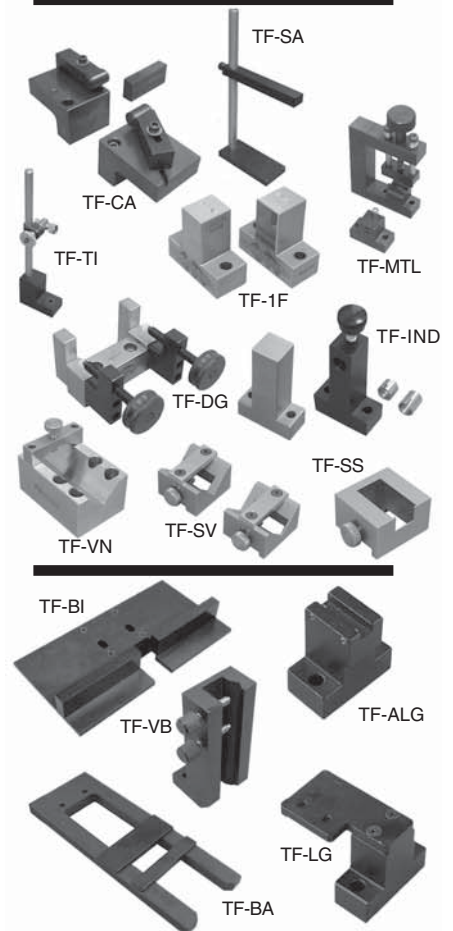

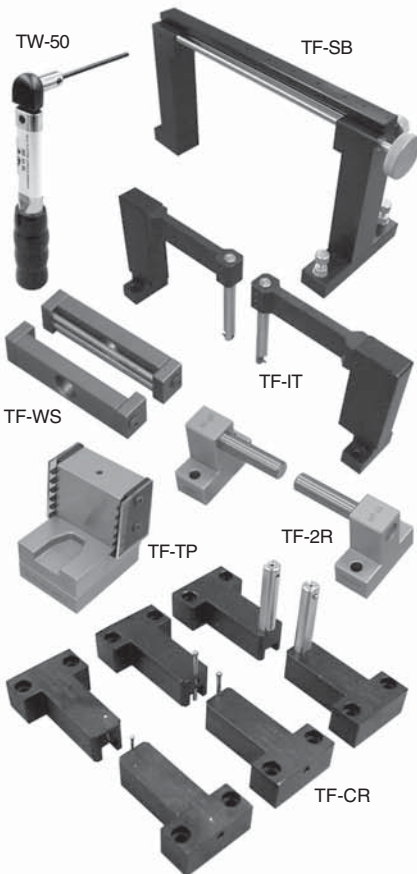
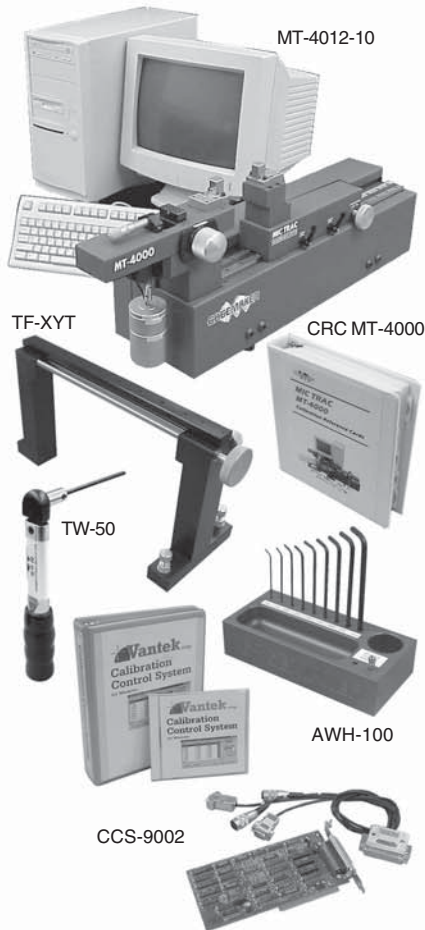

PRECISION GAGE CALIBRATION SYSTEM

This package features the MIC TRAC/MT-4000 as a precision calibration system. The system accepts fixtures that inspect and calibrate a wide range of gage diameters and thread pitches. The package includes all the equipment necessary to calibrate precision hand held gages. Ring and plug inspection requires the purchase of additional accessories.

Package includes:

- MT-4012-10 MIC TRAC electronic adjustable measurement master, range 0" to 12". Base unit is segmentally linear error corrected to an accuracy of ± 0.00005 ", resolution .00001", travel 12.000".
- Ultra precision scale with 1.00" travel, Accuracy ± 0.00002 ", resolution .00001", travel 1.000".
- Desktop computer with CCS-9002 Calibration Control Software for Windows® installed. Software has a report writer, a recall database, and a digital data acquisition module. Network compatible.
- CRC MT-4000 Calibration Reference Card Set - procedures documenting calibrations with the Gagemaker system
- TF-2R, Carbide anvil set, 3/8" diameter
- TF-XYT, Adjustable X,Y & tilt support table for use with the MIC TRAC
- CAL-PAK, Assortment of fixtures designed to hold gages for calibration
- TDWIN Thread Disk for Windows® software program, Provides critical thread dimensions for manufacturing and inspection of UN, ACME, Stub ACME, Metric, Buttress, and NPT threads.
- Torque wrench, 50 in. lb.
- AWH-100 Benchtop tool holder with wrenches
- Reusable shipping container

PGC-12-W2 PRECISION CALIBRATION PACKAGE

Training Options: Option A: Training at customer's facility (per day, plus airfare)
Option B: Training at Gagemaker's facility (per day, per person)

ADDITIONAL PACKAGES & CALIBRATION ACCESSORIES

The following base units and accessories are available for larger requirements.

Model No.	Description	Unit Price
OTHER PACKAGES		
PGC-24-W2	Above calibration package with MT-4024-10 MIC TRAC	0"-24" range
PGC-36-W2	Above calibration package with MT-4036-10 MIC TRAC	0"-36" range
PGC-48-W2	Above calibration package with MT-4048-10 MIC TRAC	0"-48" range
PRECISION CALIBRATION SYSTEM ACCESSORIES (* requires TF-2R blocks)		
TDWIN	Thread Disk for Windows® software program calculates critical thread dimensions for manufacturing and inspection of UN, ACME, Stub ACME, Metric, Buttress, and NPT threads	
TF-SB	Adjustable height support table	
TF-XYT	Adjustable height, X axis & Y axis support base	
TF-WS	Thread wire set for 6,8,10,12,14,16,18,20,24,28,32 pitch "V" threads *	
TF-CR	Set of 3 fixtures for measuring cylindrical ring gages and bores. CR-1 (.170"-.230"), CR-2 (.250"-.875"), CR-3 (.880"-Larger)	
TF-CP	Ball contact holders, .500 ID measurement.	
TF-IT	Internal threaded ring ball P.D. module (for solid style rings)	
TF-2R	3/8" dia. carbide anvil set	
TF-TP	Calibration fixture for NPT, NPTF, and ANPT tapered plug gages, Includes wire for 27, 18, 14, & 11 1/2 pitch threaded plugs.	
TF-SP	For holding gage pins vertical.	
TF-AWH	Allen wrench holder with wrenches	
TW-50	50 in-lb torque wrench w/ 5/32" hex wrench adapter	

** Wire holder modules with 1 set of wires from 1.0mm to 4.5mm.

ADDITIONAL PACKAGES & CALIBRATION ACCESSORIES *Continued*

INDIVIDUAL THREADS WIRE HOLDER MODULES *(Are supplied with one set wires-specify pitch)*

TF-WHV-XX	60° thread wire holder modules with wires 5 pitch to 48 pitch
TF-WHV-XX	60° thread wire holder modules with wires 1-4 pitch, 56-72 pitch
TF-WHA-XX	29° thread wire holder modules with wires 4 pitch to 20 pitch
TF-WHA-XX	29° thread wire holder modules with wires 2 pitch, 3 pitch
TF-WHM-XX	Metric thread wire holder modules with wires 1.0 mm -4.5mm pitch
TF-WHM-XX	Metric thread wire holder modules with wires .5mm-.8mm, 5mm-6mm pitch

CALIBRATION AND DATA COLLECTION SOFTWARE OPTIONS

INSPEX	Digital readout software with report writer and digital data acquisition module
CCS-9001	Calibration software for Microsoft® Windows™ with recall database, RS-232 interface download utility, and text file editor for inspection report writing. Customer must supply computer with CD-ROM capable of running Windows. (CALSPEX & RECALL)
CCS-9002	Gage calibration software for Microsoft® Windows™ with calibration reports, recall database, and digital data collection module. Customer must supply computer with CD-ROM capable of running Windows. (CALSPEX, RECALL & INSPEX)

MIC 360 Basic Package

The basic gage package provides everything to measure external diameters 2" to 360" and internal diameters 4" to 360" more accurately and repetitively than ever before. This package comes ready to install on any machine tool that accepts a 1¼" square tool holder. Other components and options are listed below.

Model No.	Description	Package Price
WLGH-100	Internal/external gage head with infrared receiving unit	
IRU-100	Infrared receiving unit w/ 20 ft. cable	
DSP-300	Computer CPU	
OPT-400	Standard optical light switch	
OPT-401	Optical light switch mounting bracket	
GWL-500-3.75	3.75" Diameter gage wheel	
CBL-620	Light switch cable (20 ft.)	
LI-BAT	Spare Lithium Ion battery	
LI-CHGR	Lithium Ion battery charger	
PEL-1600	Heavy duty storage and shipping case	

MIC 360 DIAMETER GAGE PACKAGE

Installation and Training (per day, plus airfare and expenses)

