

# Calibration Equipment

Due to the versatility, our Calibration Equipment is widely used throughout the inspection industry.

The MIC TRAC measurement center combines accuracy with flexibility to ideally adapt to the shop floor or to the quality lab. The proven accuracy makes the MIC TRAC a perfect choice for part inspection and serves as a setting master for gages produced by leading gage manufacturers. The unit comes in several lengths as well as different accuracies. Our MT-3000 series provides tolerance of .0001" and our MT-4000 series provides tolerance of .00003".

Customers who have implemented an in-house calibration system with the MIC TRAC not only realize a substantial savings, but achieve greater control over the inspection of their gauging equipment.



**Threaded Plug**



**Tapered Plug**

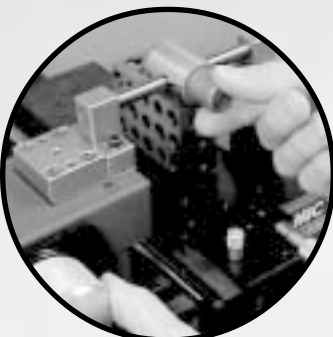

**Cylindrical Plug**





MT-3012-50

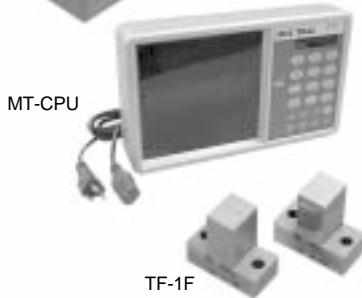

MT-CPU

TF-1F



PRN-100

PRN-000

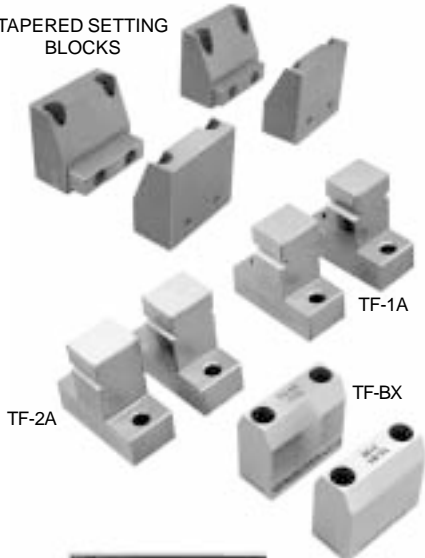
TAPERED SETTING  
BLOCKS

TF-1A

TF-BX

TF-2A



TDWIN

## GAGE SETTING SYSTEM

This package features the MIC TRAC as a multi-use gage setting system. The system sets or zeros most gages with the use of interchangeable anvils or blocks. Standard resolution of base unit is .00005". Accuracies range from  $\pm 0.0001$ " to  $\pm 0.0004$ ". (MT CPU is CE approved.)

MIC TRAC base unit w/ range: 0" to 12" with TF-1F blocks and shipping carton

**MT-3012-50 BASIC GAGE SETTING SYSTEM 6615.00**

## GAGE SETTING SYSTEM OPTIONS

Expand or upgrade the basic gage setting system with the addition of other accessories and setting blocks.

Model No.	Description	Unit Price
<b>OTHER BASE UNITS (Includes TF-1F block set)</b>		
MT-3012-50	MIC TRAC base unit w/ range: 0" to 12" internal, 1½" to 13½" external	6615.00
MT-3024-50	MIC TRAC base unit w/ range: 0" to 24" internal, 1½" to 25½" external	7980.00
MT-3036-50	MIC TRAC base unit w/ range: 0" to 36" internal, 1½" to 37½" external	12183.00
MT-3048-50	MIC TRAC base unit w/ range: 0" to 48" internal, 1½" to 49½" external	21316.00

### MIC TRAC BASE UNIT OPTIONS

PRN-100	Electronic printer for hardcopy records	475.00
PRN-000	Replacement roll of printer paper	5.95

### TAPERED CYLINDER SETTING BLOCKS (2 block sets)

TF-10	Tapered setting blocks 10° half angle	447.00
TF-15	Tapered setting blocks 15° half angle	447.00
TF-20	Tapered setting blocks 20° half angle	447.00
TF-30	Tapered setting blocks 30° half angle	447.00
TF-45	Tapered setting blocks 45° half angle	447.00

### SPECIAL PURPOSE SETTING BLOCKS

TF-1F	Flat face setting blocks (1.500" outside dim.)	397.00
TF-BX	23° angled face setting blocks	447.00

### THREAD GAGE SETTING BLOCKS

TF-1V	1-5 pitch 60° "V" thread setting blocks	447.00
TF-2V	6-20 pitch 60° "V" thread setting blocks	447.00
TF-1A	2-3 pitch ACME/STUB ACME thread setting blocks	447.00
TF-2A	4-20 pitch ACME/STUB ACME thread setting blocks	447.00

### THREAD DISK FOR WINDOWS SOFTWARE

TDWIN (replaces TD-100)	Thread Disk for Windows software for calculating critical product dimensions and Gagemaker style gage setting values for inspecting ANSI thread forms. The program also provides information for certifying ring and plug gages.	375.00
TDWIN-UP	Upgrade to TD-WIN from TD-100	149.00

## HAND GAGE CALIBRATION SYSTEM

This package features the MIC TRAC as a multi-use gage calibration system. The system uses interchangeable anvils to calibrate a variety of handheld style gages. Through the various configurations of fixtures, the MIC TRAC achieves an accuracy of  $\pm 0.0001$ " (cumulative per every 12" of travel). Resolution is  $.00005$ ". (MT CPU is CE approved.)

### Package includes:

- MT-3012-50 MIC TRAC base unit w/ range: 0" to 12", includes TF-1F blocks and shipping carton.
- CAL-PAK, complete calibration fixture package
- CRC-MT3000 Calibration Reference Cards - Calibration procedures for use with CAL-PAK

### HGC-12-HT HAND GAGE CALIBRATION PACKAGE 9989.00

### GAGE CALIBRATION SYSTEM OPTIONS

The following base units and accessories are available for larger requirements.

Model No.	Description	Unit Price
<b>OTHER PACKAGES</b>		
HGC-24-HT	Above calibration package with MT-3024-50, w/ range 0" to 24"	11354.00
HGC-36-HT	Above calibration package with MT-3036-50, w/ range 0" to 36"	15557.00
HGC-48-HT	Above calibration package with MT-3048-50, w/ range 0" to 48"	24690.00
<b>SYSTEM PRINTER AND PAPER</b>		
PRN-100	Electronic printer for hardcopy records	475.00
PRN-000	Replacement printer paper	5.95
<b>CALIBRATION ACCESSORY BLOCKS AND FIXTURES</b>		
CAL-PAK	Complete calibration package Includes: TF-IND, TF-DG, TF-CA, TF-SA, TF-TI, TF-SV, TF-SS, TF-VN, TF-MTL, and storage case	2779.00
TF-IND	AGD dial indicator calibration fixture (includes .375" and 8mm bushing and TF-2F block)	147.00
TF-DG	Calibration fixture for depth micrometer *	425.00
TF-CA	Caliper calibration accessory dial, digital and vernier calipers. Includes TF-SA support arm.	387.00
TF-TI	Test indicator calibration block *	137.00
TF-SV	"V" Support accessory ** for calibrating micrometers and standards	497.00
TF-SS	Straight support accessory * for support of extended probes	265.00
TF-VN	"V" blocks for calibration of axial travel probes and bore gages	297.00
TF-MTL	Micrometer spindle thread lead calibration fixture.	597.00
TF-1F	Flat face setting block set (2 blocks) 1.5000" outside dimension	397.00
TF-BA	Base support block for setting dial bore gages **	295.00
TF-VB	"V" block fixture for calibration of Gagemaker's TH-3004 and MRP-2002 Upper arms *	239.00
TF-LG	Gagemaker lead gage calibration fixture *	227.00
TF-ALG	Lead gage calibration fixture *	227.00
TF-BI	Base support plate for setting dial bore gages **	397.00
	* 1/TF-1F block required with this accessory	
	** 2/TF-1F blocks required with this accessory	
CRC-MT4000	Complete procedural documentation for the calibration of handheld inspection	595.00
CRC-MT3000	Equipment including; O.D. & I.D. micrometers, calipers, depth micrometers, ring and plug gages, and more.	

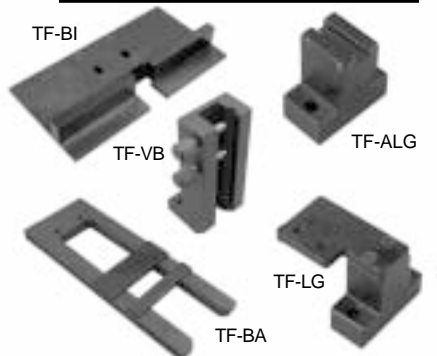
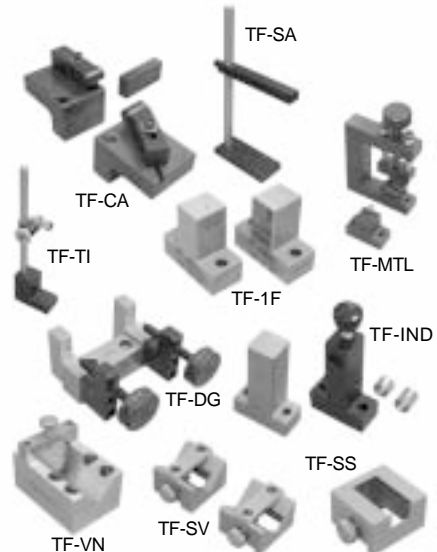



## PRECISION GAGE CALIBRATION SYSTEM

This package features the MIC TRAC/MT-4000 as a precision calibration system. The system accepts fixtures that inspect and calibrate a wide range of gage diameters and thread pitches. The package includes all the equipment necessary to calibrate precision hand held gages. Ring and plug inspection requires the purchase of additional accessories.

Package includes:

- MT-4012-10 MIC TRAC electronic adjustable measurement master, range 0" to 12". Base unit is segmentally linear error corrected to an accuracy of  $\pm 0.00005$ ", resolution .00001", travel 12.000".
- Ultra precision scale with 1.00" travel, Accuracy  $\pm 0.00002$ ", resolution .00001", travel 1.000".
- Desktop computer with CCS-9002 Calibration Control Software for Windows® installed. Software has a report writer, a recall database, and a digital data acquisition module. Network compatible.
- CRC MT-4000 Calibration Reference Card Set - procedures documenting calibrations with the Gagemaker system
- TF-2R, Carbide anvil set, 3/8" diameter
- TF-XYT, Adjustable X,Y & tilt support table for use with the MIC TRAC
- CAL-PAK, Assortment of fixtures designed to hold gages for calibration
- TDWIN Thread Disk for Windows® software program, Provides critical thread dimensions for manufacturing and inspection of UN, ACME, Stub ACME, Metric, Buttress, and NPT threads.
- Torque wrench, 50 in. lb.
- AWH-100 Benchtop tool holder with wrenches
- Reusable shipping container

### PGC-12-W2 PRECISION CALIBRATION PACKAGE 29666.00

**Training Options:** Option A: Training at customer's facility (per day, plus airfare) 1000.00  
 Option B: Training at Gagemaker's facility (per day) 500.00

## ADDITIONAL PACKAGES & CALIBRATION ACCESSORIES

The following base units and accessories are available for larger requirements.

Model No.	Description	Unit Price
<b>OTHER PACKAGES</b>		
PGC-24-W2	Above calibration package with MT-4024-10 MIC TRAC 0"-24" range	31030.00
PGC-36-W2	Above calibration package with MT-4036-10 MIC TRAC 0"-36" range	35234.00
PGC-48-W2	Above calibration package with MT-4048-10 MIC TRAC 0"-48" range	44366.00

<b>PRECISION CALIBRATION SYSTEM ACCESSORIES (* requires TF-2R blocks)</b>		
TDWIN	Thread Disk for Windows® software program calculates critical thread dimensions for manufacturing and inspection of UN, ACME, Stub ACME, Metric, Buttress, and NPT threads	375.00
TF-SB	Adjustable height support table	1897.00
TF-WS	Thread wire set for 6,8,10,12,14,16,18,20,24,28,32 pitch "V" threads *	1497.00
TF-CR	Set of 3 fixtures for measuring cylindrical ring gages and bores. CR-1 (.170"-.230"), CR-2 (.250"-.875"), CR-3 (.880"-Larger)	1397.00
TF-IT	Internal threaded ring ball P.D. module (for solid style rings)	1616.00
TF-2R	3/8" dia. carbide anvil set	797.00
TF-TP	Calibration fixture for NPT, NPTF, and ANPT tapered plug gages, Includes wire for 27, 18, 14, & 11 1/2 pitch threaded plugs.	1097.00
TW-50	50 in-lb torque wrench w/ 5/32" hex wrench adapter	197.00

<b>INDIVIDUAL THREADS WIRE HOLDER MODULES (Are supplied with one set wires-specify pitch)</b>		
TF-WHV-XX	60° thread wire holder modules with wires 5 pitch to 48 pitch	143.00 ea
TF-WHV-XX	60° thread wire holder modules with wires 1-4 pitch, 56-72 pitch	171.00 ea
TF-WHA-XX	29° thread wire holder modules with wires 4 pitch to 20 pitch	208.00 ea
TF-WHA-XX	29° thread wire holder modules with wires 2 pitch, 3 pitch	231.00 ea
TF-WHM-XX	Metric thread wire holder modules with wires 1.0 mm -4.5mm pitch	143.00 ea
TF-WHM-XX	Metric thread wire holder modules with wires .5mm-.8mm, 5mm-6mm pitch	171.00 ea
TF-WH-XX	Wire holder only (specify wire size)	110.00 ea

**ADDITIONAL PACKAGES & CALIBRATION ACCESSORIES *Continued***

**GENERAL PART MEASUREMENT ACCESSORIES**

TF-SB	Adjustable height support base	1897.00
TF-XYT	Adjustable height, x-axis, and y-axis support base	3421.00
TF-CP	Ball contact holders, .500" min. I.D. measurement	397.00
TF-CR	Set of 3 fixtures for measuring cylindrical ring gages and bores. CR-1 (.170"-.230"), CR-2 (.250"-.875"), CR-3 (.880"-Larger)	1397.00
TF-SP	For holding gage pins vertical	497.00
TW-50	50 in-lb torque wrench w/ 5/32" hex wrench adapter	197.00

**CALIBRATION AND DATA COLLECTION SOFTWARE OPTIONS**

INSPEX	Digital readout software with report writer and digital data aquisition module	2745.00
CCS-9001	Calibration software for Microsoft® Windows™ with recall database, RS-232 interface download utility, and text file editor for inspection report writing. Customer must supply computer with CD-ROM capable of running Windows. (CALSPEX & RECALL)	3292.00
CCS-9002	Gage calibration software for Microsoft® Windows™ with calibration reports, recall database, and digital data collection module. Customer must supply computer with CD-ROM capable of running Windows. (CALSPEX, RECALL & INSPEX)	4792.00

